



PALSHIELD™

Containment & Ballistic Glazing

Installation Guide



Build On.

General Information

The glazing of Palshield laminated polycarbonate should be considered a finishing operation in new construction and scheduled as the final step in the completion of the building.

Care should be taken to protect the surface of the sheet during storage, fabrication, transportation and installation. Once all construction trades are complete, the protective masking can be removed.

If the protective masking will be exposed to high humidity or direct sunlight after installation, it is recommended it be removed and covered with a polyethylene or fabric tarp. Prolonged exposure to high humidity and direct sunlight can make the protective masking difficult to remove.

Glazing Terminology

1. **Palshield Laminate** – Polycarbonate sheet manufactured by placing layer on layer, together with other polymers or films.
2. **Frame** – A rigid structure that surrounds or encloses something such as a window.
3. **Glazing Tape, Gasket or Sealant** – Material used to seal the junction between two surfaces.
4. **Setting Block** – Small blocks made of neoprene, vinyl, etc., to distribute the weight of the Palshield to the strong point of a sash or frame, to aid in centering the Palshield, and to prevent Palshield-to-metal contact.
5. **Glazing Stop** – The part of the sash or door panel which holds the Palshield in place.
6. **Face Clearance** – The dimension measured between the face plane of a panel of Palshield and the nearest face of its retaining frame or stop.
7. **Edge Clearance** – The dimension between the edge of the Palshield and its surrounding frame. Inadequate edge clearance can result in damage to the Palshield by Palshield-to-metal contact.
8. **Edge Engagement** – Depth of Palshield engagement within the glazing channel; also termed “bite”
9. **Rabbit Depth** – In glazing, the depth of the glazing rabbet; equal to the sum of the bite and the edge clearance.
10. **Thermal Expansion** – Thermal expansion is the tendency of matter to change in volume in response to a change in temperature. All materials have this tendency, including Palshield. See section titled “Palshield Thermal Expansion Allowance.”

Installation Methods and Frame Design

For interior ballistic and security applications where temperatures are relatively constant, Palshield can be installed using a wet or dry glazing method. Both methods will require the framing to accommodate a minimum 1" edge engagement. Both methods of glazing shall utilize glazing materials proven compatible with Palshield laminated polycarbonate. Framing members must be weeped, designed for support, allow expansion and provide proper edge and face clearance without causing abnormal mechanical stresses on the Palshield sheet. Overall rabbet depth depends on the length or width of the glazing.

Installation Procedures

1. Clean sash surface and prime if necessary. If installing replacement glazing, be sure all old sealant and any remaining residue are removed. Rabbet should be free of all burrs and projections.
2. Carefully measure sash opening and ensure it meets recommended edge engagement and thermal expansion allowance (See Table 1.0 and 1.1). Cut sheet to required size being sure to maintain a clean edge free of notches and protrusions.
3. Glaze the PALSHIELD sheet using only Palram approved, polycarbonate compatible materials. See Table 2.0. All seals must be tight to prevent penetration by water, solvents, vapors or cleaning agents. Prolonged edge exposure to water or chemicals can cause hazing, edge cracks and delamination.
4. Remove protective masking after installation is complete. Do not expose the protective masking to high humidity and direct sunlight. Prolonged exposure can lead to difficulty when removing the protective masking.

Basic Frame Design

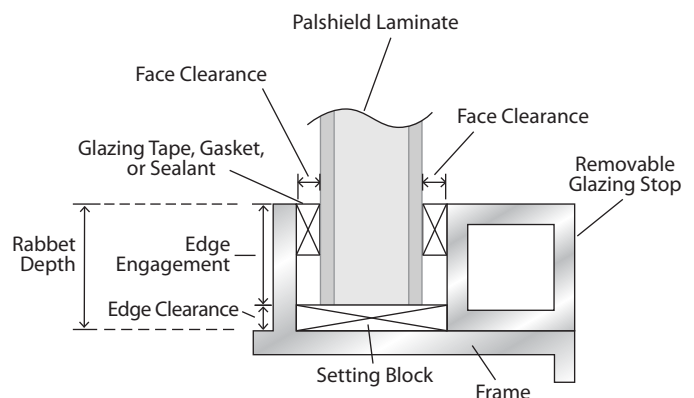

Palshield Thermal Expansion Allowance

For exterior applications, the installer must consider the additional movement of the sheets due to thermal expansion. Reference Table 1.0 when calculating thermal expansion of Palshield sheets.

Table 1.0 Calculation Example

Thermal Expansion Calculation Formula = .000036" x Temperature Span x Length

Size of Sheet for Example Calculation	48" x 96" Sheet of Palshield
Assumptions for Example Calculation	Installation temperature of 60°F with a maximum high temp of 110°F and minimum low temp of 10°F.
Expansion	000036 x 50° x 96" = .173"
Contraction	.000036 x 50° x 96" = .173"
Combined Expansion and Contraction	.346"
Recommended edge engagement for Palshield	1.00"
Total Rabbet Depth =	1.00" + .346" = 1.346"

Table 1.1 Quick Reference Guide: Thermal Expansion Allowance

Glazing Dimensions	Up to 24"	25" to 36"	37" to 48"	49" to 60"	61" to 72"	73" to 96"
Recommended edge engagement for Palshield laminates	1"					
Expansion	0.043"	0.065"	0.086"	0.108"	0.130"	0.173"
Contraction	0.043"	0.065"	0.086"	0.108"	0.130"	0.173"
Total Rabbet Depth	1.09"	1.13"	1.17"	1.22"	1.26"	1.35"

The calculations in the table above are based on the assumption of a 50° temperature change from installation temperature.

See Table 2.0 for a brief list of approved glazing materials. Should you have any questions regarding glazing materials and their compatibility with polycarbonate, please contact Palram Americas technical support for assistance.

Table 2.0 Recommended Sealants, Gaskets and Tapes

Product Type	Product Name			Manufacturer
Silicone	Dow 795	Dow 999	Trademate	Dow-Corning Corp
Silicone	Silpruf Construction Sealant 120			GE Silicones
Silicone	Spectrem			Tremco
Gasket	EPDM (60,70D)			Tremco
Tape	440			Tremco
Gasket/Tape	Norrene Foam V-2100 Urethan			Norton Company
Butyl Tape	Isocryl 5600			Schnee-Morehead

There are many other glazing materials available which are compatible with Palshield. It is the responsibility of the customer to verify compatibility of other materials prior to installation.

Cleaning and Maintenance

Wash with mild soap or detergent and rinse thoroughly with clean water. Take care not to scratch the surface of the Palshield by using a soft cloth or sponge when cleaning. To prevent water spots, thoroughly dry the glazing with a chamois or moist sponge. Do not use abrasive cleaners or solvents. Avoid cleaning in direct sun to reduce streaking.

Compatible Cleaners

The following agents and cleaners have been approved and are compatible with Palshield when used per manufacturers recommendations: • Formula 409® • Top Job®, Joy® • Palmolive® Liquid • Windex® D with Ammonia D

For more information, technical literature and warranty details please call 800-999-9459, or visit our website at www.palramamericas.com/palshield.



PALRAM AMERICAS

9735 Commerce Circle, Kutztown, PA 19530
Phone: 610-285-9918 (Toll Free: 800-999-9459)
Fax: 610-285-9928
E-mail: PalramAmericas@palram.com
Web Site: www.PalramAmericas.com



Distributed By:

Form # 2301 • Rev. 12/04, 2012, PBW



Inasmuch as Palram Americas has no control over the use to which others may put the product, it does not guarantee that the same results as those described herein will be obtained. Each user of the product should make his own tests to determine the product's suitability for his own particular use including the suitability of environmental conditions for the product. Statements concerning possible or suggested uses of the products described herein are not to be construed as constituting a license under any Palram Americas patent covering such use or as recommendations for use of such products in the infringement of any patent. Palram Americas or its distributors cannot be held responsible for any losses incurred through incorrect installation of the product. In accordance with our company policy of continual product development you are advised to check with your local Palram Americas supplier to ensure that you have obtained the most up to date information.

Palram reserves the right to change product specifications and/or information contained in this brochure without notice.

© 2011 Palram Industries, Ltd. | Palshield is a trademark of Palram Industries Ltd. All other trademarks are registered by their respective holders.